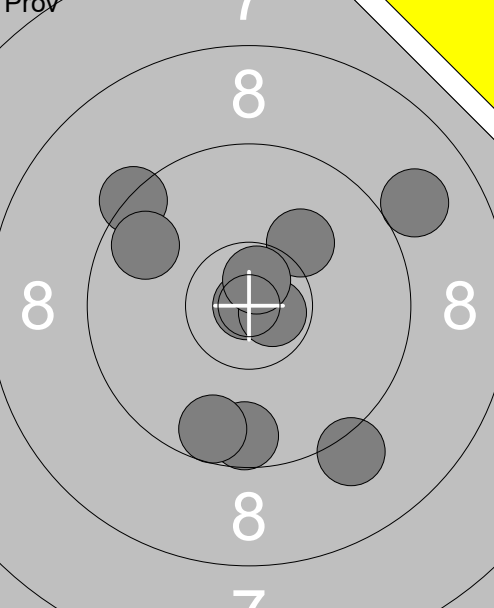
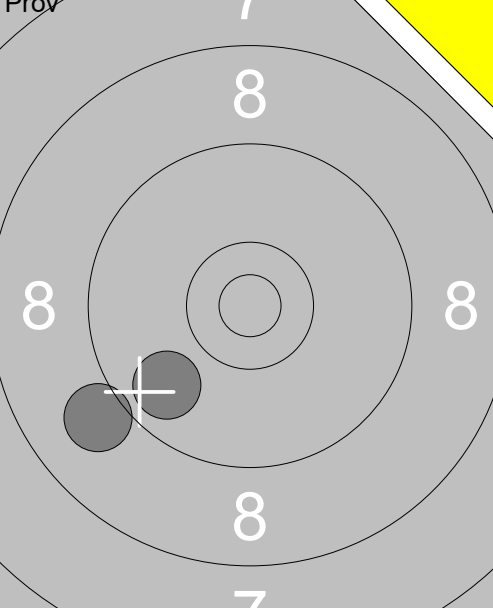
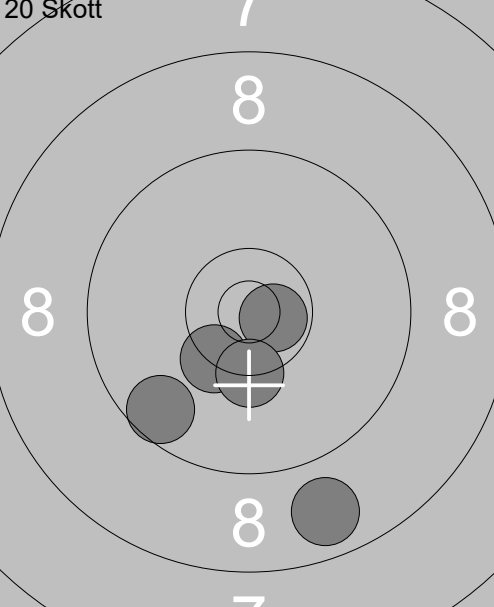
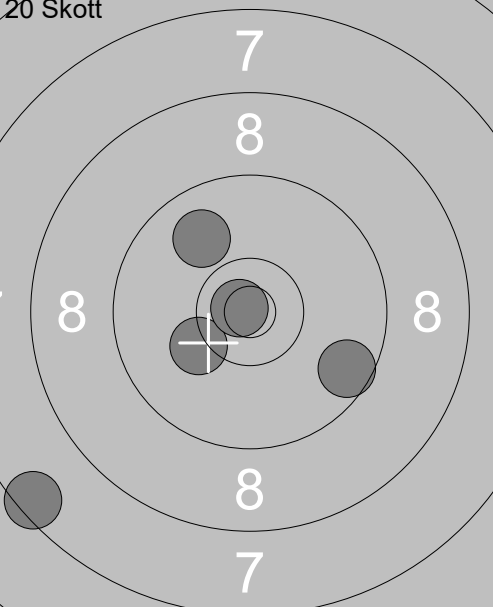
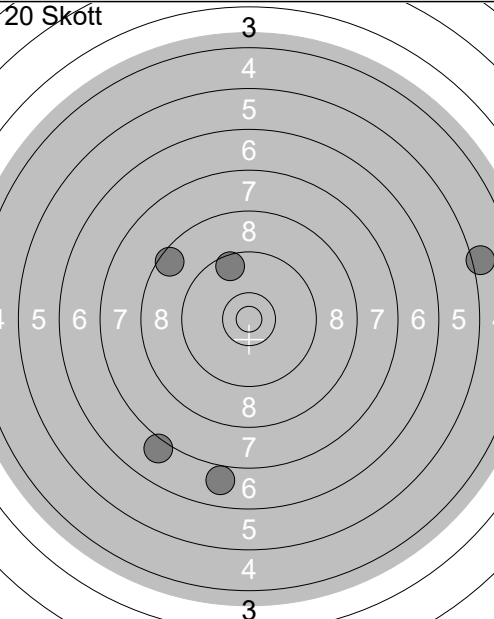
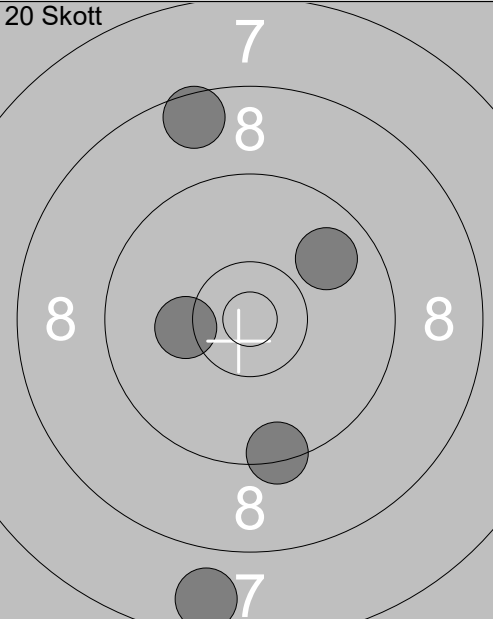
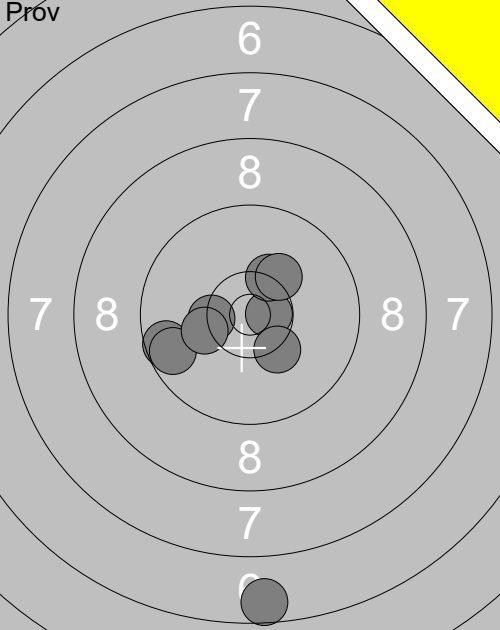
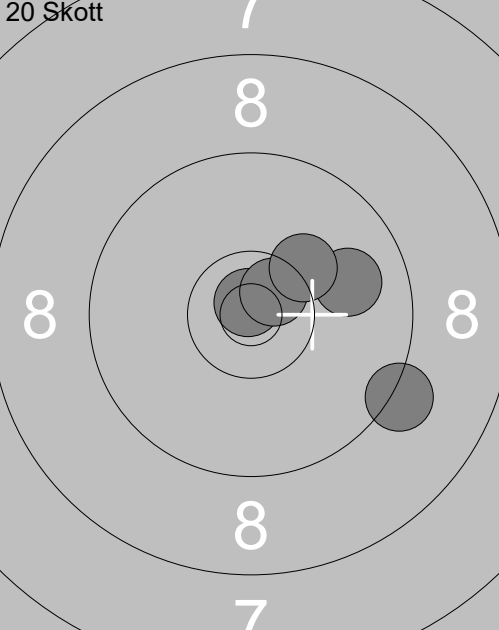
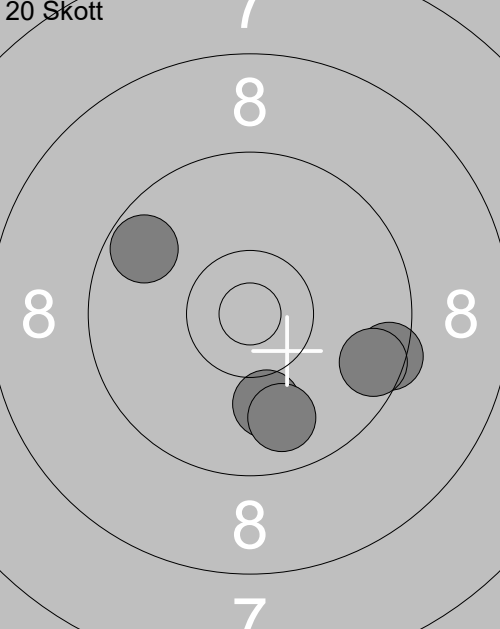
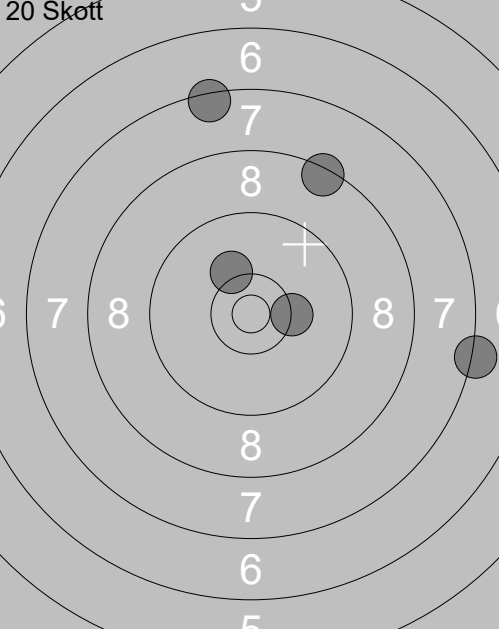
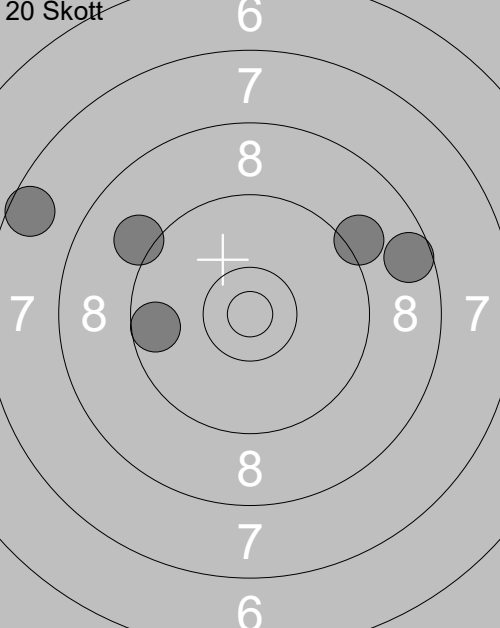
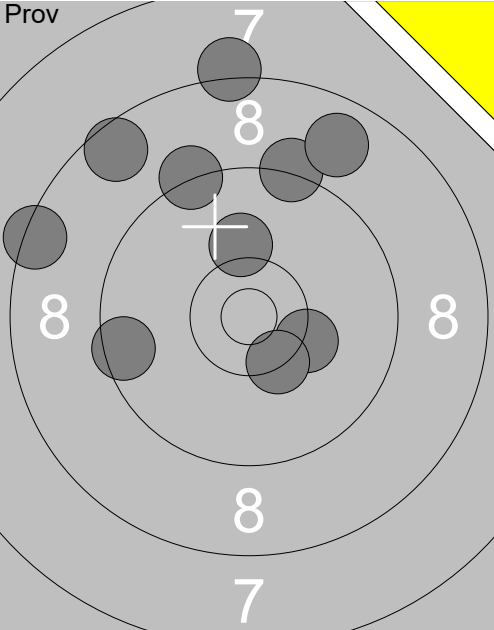
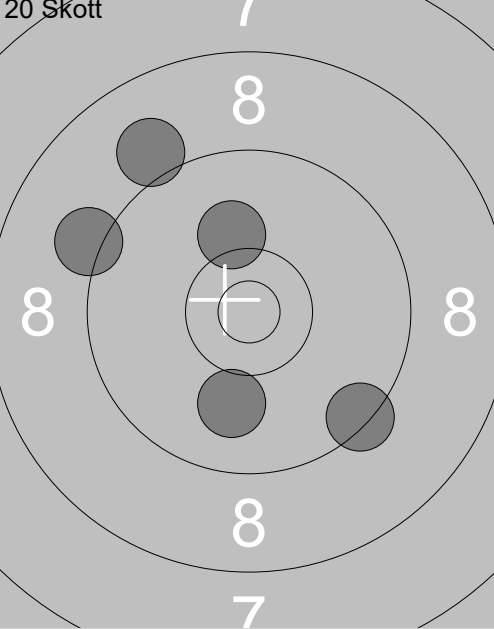
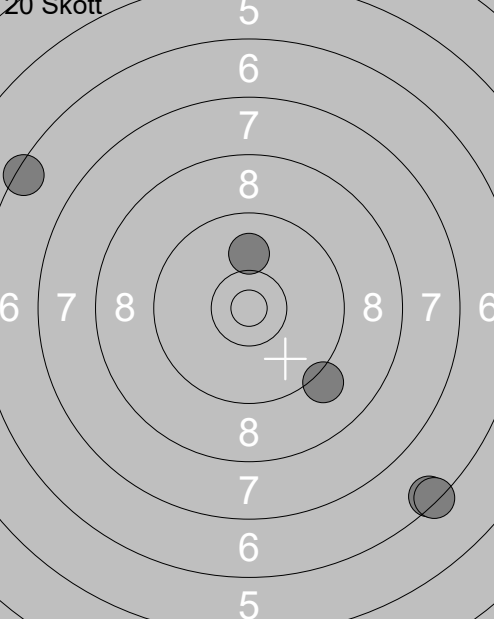

Skjutlag	Tavla	Peter Fransson	
4	1	50 m Skövde	Vet
28.07.2017	SM 50 Ställning	Skaraborgs skytteförbund	
Pröv 	1: 8.9 ↘ 2: 9.1 → 3: 9.8 ↘ 4: 8.0 ← 5: 9.7 ↘ 6: 10.4x↘ 7: 9.7 ← 8: 10.3x↘ 9: 8.7 ← 10: 9.9 ← Serie 89.0 Total 0.0	Pröv 	11: 10.1 ↘ 12: 10.0 ↖ 13: 8.9 → Serie 28.0 Total 0.0
20 Skott 	1: 9.4 ↘ 2: 10.4x↘ 3: 8.7 → 4: 9.2 ↗ 5: 10.6x↗ Serie 46.0 Total 46.0	20 Skott 	6: 10.3 ↘ 7: 10.1 ↖ 8: 10.5x↘ 9: 9.7 ↗ 10: 10.4x↘ Serie 49.0 Total 95.0
20 Skott 	11: 7.4 ↖ 12: 8.1 ← 13: 6.5 ↖ 14: 7.3 ↘ 15: 2.8 ↗ Serie 30.0 Total 125.0	20 Skott 	16: 9.5 ↗ 17: 7.8 → 18: 10.5x↗ 19: 9.9 → 20: 10.3x↗ Serie 45.0 Total 170.0

Skaraborgs skytteförbund

	<p>1: 9.0 ↗ 2: 9.1 ↓ 3: 9.6 ↓ 4: 9.6 ↓ 5: 9.4 ↖ 6: 10.9x← 7: 10.7x→ 8: 10.1 ↗ 9: 10.7x↗ 10: 9.7 ↖</p> <p>Serie 94.0 Total 0.0</p>		<p>11: 9.8 ↙ 12: 9.0 ↙</p> <p>Serie 18.0 Total 0.0</p>
	<p>1: 10.4x↘ 2: 8.8 ↓ 3: 9.6 ↓ 4: 10.7x→ 5: 10.3x↓</p> <p>Serie 47.0 Total 47.0</p>		<p>6: 9.9 ↖ 7: 9.6 ↗ 8: 10.2 ↙ 9: 7.5 ↙ 10: 10.8x←</p> <p>Serie 45.0 Total 92.0</p>
	<p>11: 8.5 ↖ 12: 5.1 → 13: 6.9 ↓ 14: 9.6 ↖ 15: 7.1 ↙</p> <p>Serie 35.0 Total 127.0</p>		<p>16: 7.7 ↓ 17: 8.6 ↖ 18: 9.4 ↓ 19: 10.2← 20: 9.8 ↗</p> <p>Serie 43.0 Total 170.0</p>

Skjutlag <b>4</b>	Tavla <b>3</b>	<b>Mattias Pettersson</b>	
50 m Skövde		Ingelstad SKK	Öppen
28.07.2017		SM 50 Ställning	Skaraborgs skytteförbund
Pröv		1: 6.6 ↓ 2: 10.7x→ 3: 10.4x← 4: 10.3 ↓ 5: 9.6 ← 6: 9.7 ← 7: 10.3x↗ 8: 10.2← 9: 10.2 ↗	20 Skott
		Serie 84.0	
		Total 0.0	1: 10.8x↖ 2: 9.2 ↘ 3: 9.9 → 4: 10.6x↗ 5: 10.2 ↗
			Serie 48.0
			Total 48.0
20 Skott		6: 10.0 ↓ 7: 9.8 ↓ 8: 9.5 → 9: 9.6 → 10: 9.7 ↖	20 Skott
		Serie 46.0	
		Total 94.0	11: 8.4 ↗ 12: 10.2 ↖ 13: 7.2 → 14: 7.4 ↑ 15: 10.3→
			Serie 42.0
			Total 136.0
20 Skott		16: 8.6 → 17: 9.1 ↗ 18: 7.6 ← 19: 9.6 ← 20: 9.1 ↖	
		Serie 42.0	
		Total 178.0	

Skjuttlag	Tavla	Ingemar Gustavsson	
4	4	50 m Skövde	Skövde SKG
28.07.2017	SM 50 Ställning	Skaraborgs skytteförbund	
Prov		1: 9.3 ↗ 2: 8.2 ↑ 3: 10.2 ↑ 4: 9.3 ↑ 5: 10.3 → 6: 8.8 ↗ 7: 9.5 ← 8: 8.6 ↗ 9: 10.4x ↘ 10: 8.4 ← Serie 89.0 Total 0.0	11: 9.3 ↓ 12: 9.0 13: 8.8 14: 8.8 15: 8.8 16: 8.8 17: 8.8 18: 8.8 19: 8.8 20: 8.8 Serie 9.0 Total 0.0
20 Skott		1: 9.2 ← 2: 9.4 ↘ 3: 9.0 ↗ 4: 10.0 ↓ 5: 10.1 ↑ Serie 47.0 Total 47.0	6: 7.9 ↗ 7: 8.9 ← 8: 10.4x → 9: 10.6x ↑ 10: 10.2 ↓ Serie 45.0 Total 92.0
20 Skott		11: 6.4 ↓ 12: 9.1 ↘ 13: 6.4 ↗ 14: 6.4 ↓ 15: 10.0 ↑ Serie 37.0 Total 129.0	16: 6.2 ↓ 17: 8.4 ↓ 18: 9.8 ↑ 19: 8.8 → 20: 9.3 ↓ Serie 40.0 Total 169.0

Skaraborgs skytteförbund

Skjutlag	Tavla	Alf Karlsson	
4	6	Ala-Gammelgarn	Vet
28.07.2017	SM 50 Ställning	Skaraborgs skytteförbund	
Prov		1: 9.9 ↗ 2: 8.6 ↓ 3: 9.4 ↓ 4: 8.0 ↘ 5: 9.9 ↗ 6: 9.8 ↙ 7: 10.6x ↘ 8: 9.1 ↖ 9: 10.2 ↗ 10: 9.3 ↖	Prov
	11: 9.9 ↖ 12: 8.1 ← 13: 7.6 ← 14: 9.2 ↘	Serie 90.0	Serie 33.0
Total 0.0	Total 0.0	Total 0.0	Total 0.0
20 Skott		1: 10.8x ↗ 2: 9.7 ↘ 3: 6.7 ↘ 4: 10.2 ↖ 5: 8.1 ↓	20 Skott
	6: 9.0 ↓ 7: 10.4x ↗ 8: 10.6x ↘ 9: 10.6x ↗ 10: 9.9 ↓	Serie 43.0	Serie 48.0
Total 43.0	Total 43.0	Total 91.0	Total 91.0
20 Skott		11: 9.0 ↓ 12: 7.0 ↘ 13: 4.8 ↓ 14: 7.4 ↑ 15: 9.2 ↗	20 Skott
	16: 9.2 ↓ 17: 10.8x ↘ 18: 8.9 ↑ 19: 9.2 ↘ 20: 8.9 ←	Serie 36.0	Serie 44.0
Total 127.0	Total 127.0	Total 171.0	Total 171.0

Skaraborgs skytteförbund

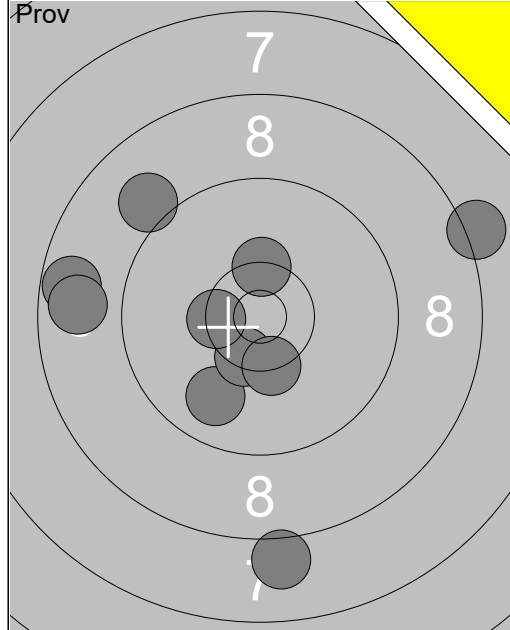

1:	8.2	➔
2:	9.9	⏚
3:	10.3x	⏚
4:	10.4x	⏚
5:	8.0	⏚
6:	8.7	⏚
7:	8.8	⏚
8:	10.4x	⏚
9:	9.0	⏚
10:	10.3x	⏚
Serie		90.0
Total		0.0

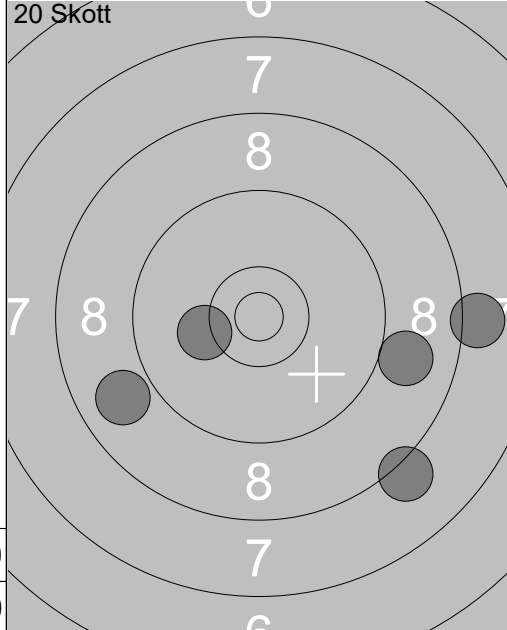

1:	9.0	➔
2:	8.1	➔
3:	8.1	⏚
4:	8.9	⏚
5:	10.2	⏚
Serie		43.0
Total		43.0

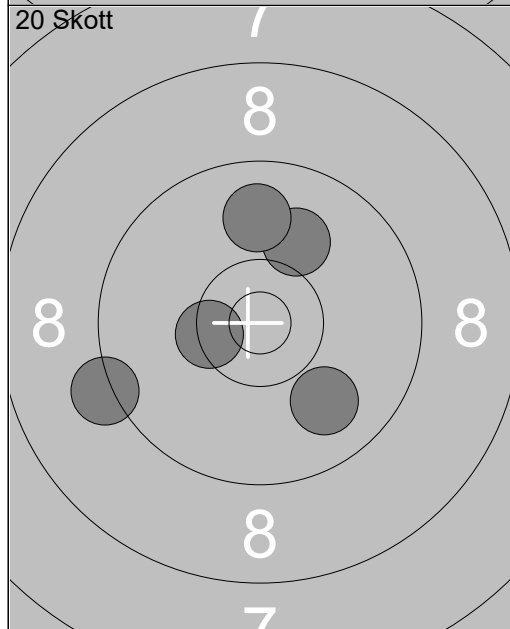

6:	9.9	⏚
7:	9.2	⏚
8:	10.4x	⏚
9:	10.0	⏚
10:	9.9	⏚
Serie		47.0
Total		90.0

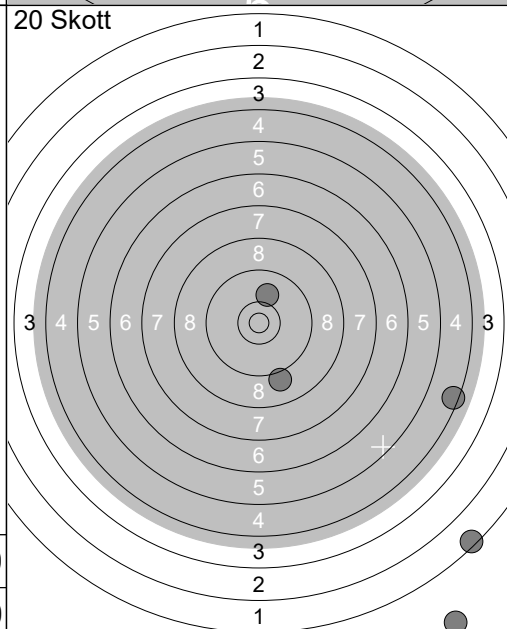

11:	10.0	⏚
12:	0.0	⏚
13:	9.1	⏚
14:	4.5	➔
15:	1.4	⏚
Serie		24.0
Total		114.0

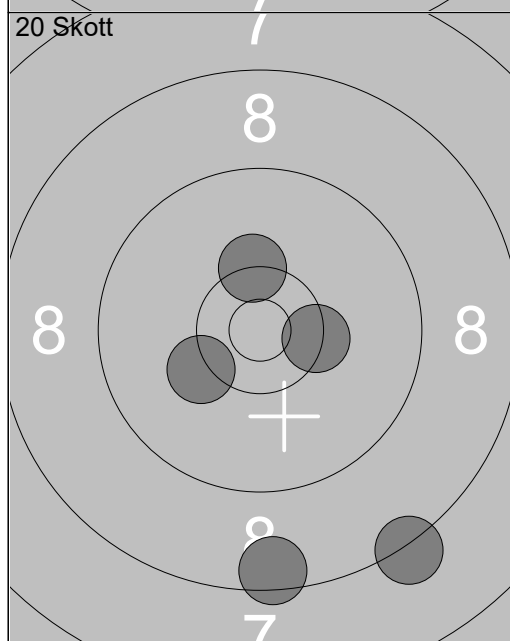

16:	10.2	⏚
17:	8.5	⏚
18:	8.2	⏚
19:	10.3x	⏚
20:	10.4x	➔
Serie		46.0
Total		160.0

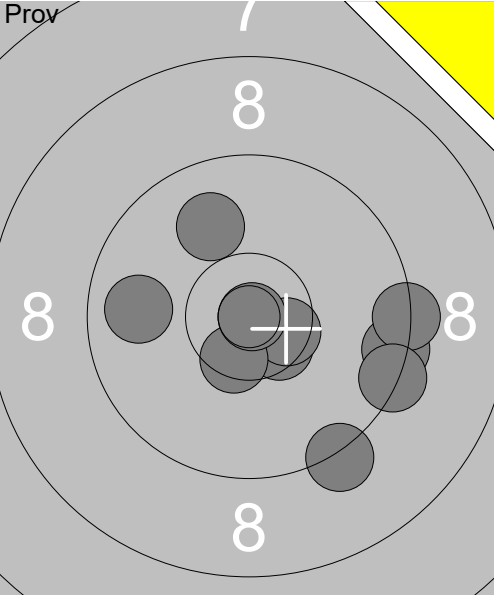
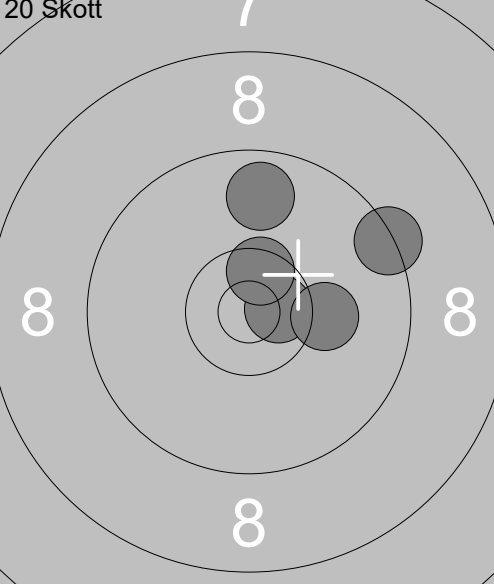
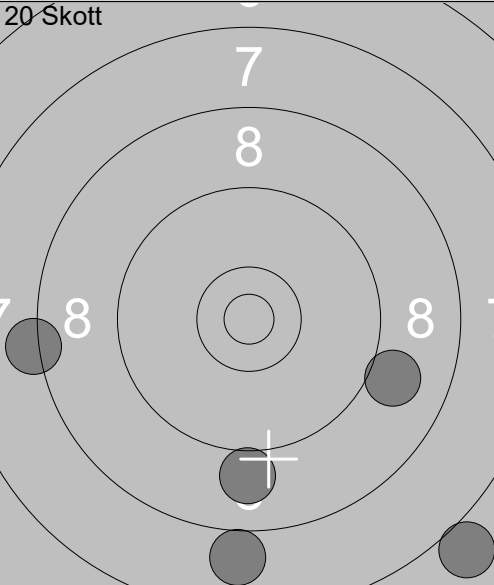
Skjutlag <b>4</b>	Tavla <b>8</b>	<b>Marie Jansson</b>	
50 m Skövde		Össjö SKF	Öppen
28.07.2017		SM 50 Ställning	Skaraborgs skytteförbund
Prov		1: 9.2 ↘ 2: 10.5x↘ 3: 10.5x→ 4: 9.4 → 5: 9.3 → 6: 9.4 → 7: 9.8 ← 8: 10.5x↘ 9: 9.9 ↑ 10: 10.9x→	11: 10.2 ↖ 12: 10.0 ↗ 13: 9.3 ← 14: 10.4x↗
		Serie 94.0	Serie 39.0
		Total 0.0	Total 0.0
20 Skott		1: 10.6x→ 2: 9.4 ↗ 3: 10.5x↗ 4: 9.8 ↑ 5: 10.2→	6: 9.9 ↖ 7: 10.6x↗ 8: 10.7x↗ 9: 10.0 ↗ 10: 9.0 →
		Serie 48.0	Serie 48.0
		Total 48.0	Total 96.0
20 Skott		11: 8.0 ↓ 12: 7.0 ↘ 13: 9.0 → 14: 8.2 ← 15: 9.0 ↓	16: 10.0 ↓ 17: 9.1 ↘ 18: 9.3 ↘ 19: 10.0 ↘ 20: 10.4x↗
		Serie 41.0	Serie 48.0
		Total 137.0	Total 185.0

Skaraborgs skytteförbund

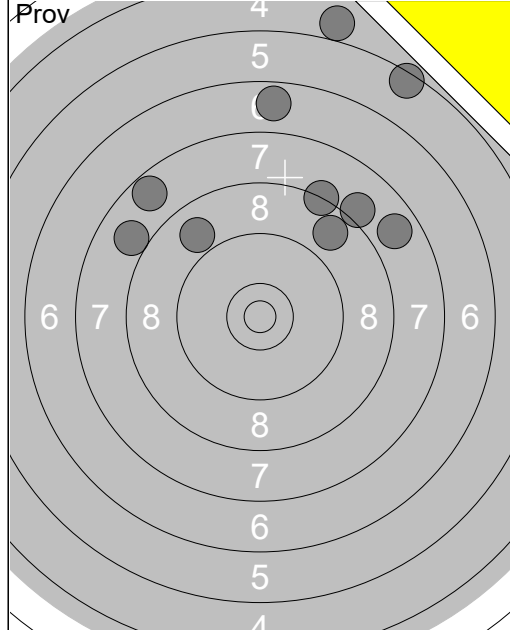

1:	5.5 ↗
2:	8.8 ↗
3:	5.0 ↑
4:	8.1 ↗
5:	8.3 ↑
6:	6.7 ↑
7:	7.8 ↗
8:	8.9 ↖
9:	8.0 ↖
10:	7.7 ↖
<b>Serie</b>	<b>70.0</b>
<b>Total</b>	<b>0.0</b>

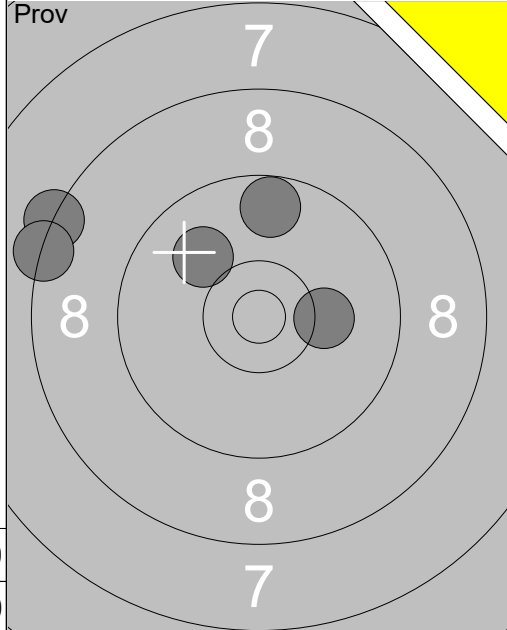

11:	9.7 ↑
12:	10.0 ↖
13:	8.3 ↖
14:	8.3 ↖
15:	10.2 →
<b>Serie</b>	<b>45.0</b>
<b>Total</b>	<b>0.0</b>

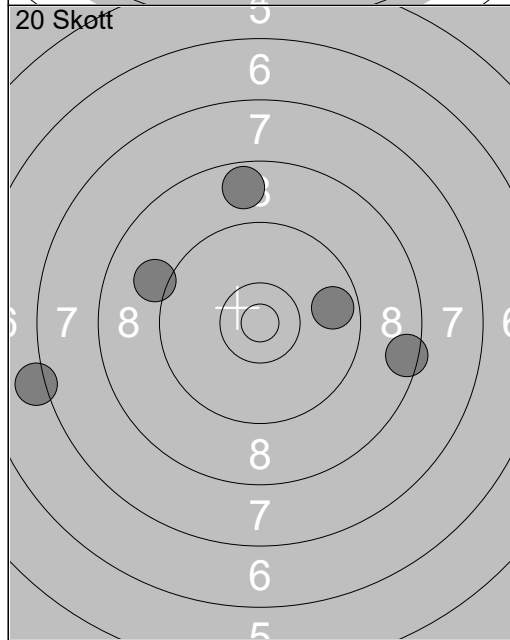

1:	9.1 ↖
2:	8.7 ↑
3:	8.5 →
4:	9.7 →
5:	7.2 ↖
<b>Serie</b>	<b>41.0</b>
<b>Total</b>	<b>41.0</b>

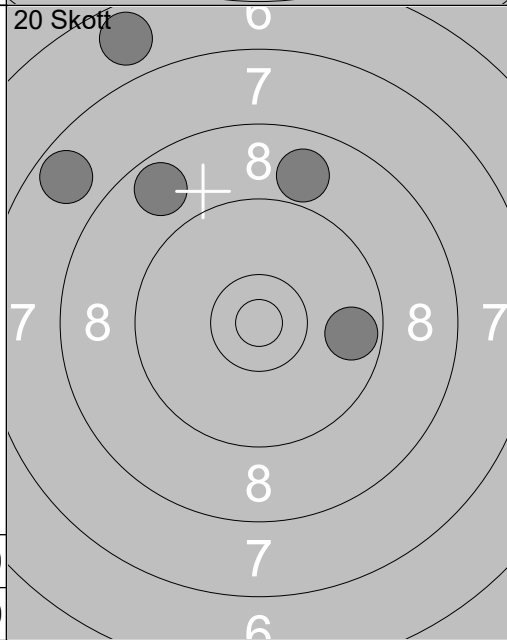

6:	8.7 ↖
7:	6.8 ↖
8:	8.9 ↑
9:	7.7 ↖
10:	9.7 →
<b>Serie</b>	<b>38.0</b>
<b>Total</b>	<b>79.0</b>

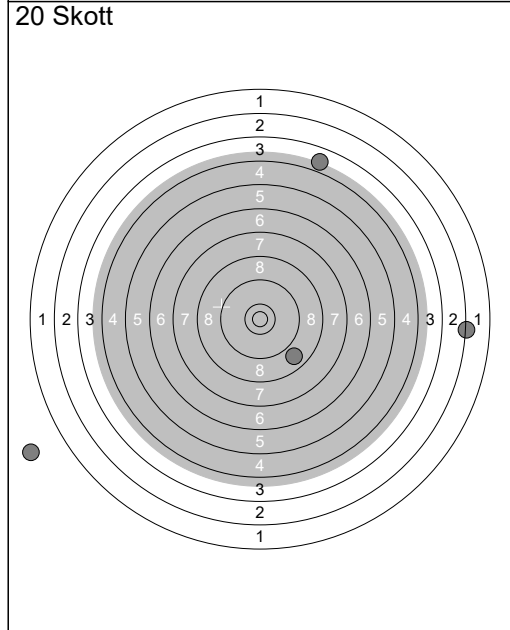

11:	2.3 →
12:	0.0 ↖
13:	0.0 ↖
14:	8.8 ↘
15:	3.9 ↑
<b>Serie</b>	<b>13.0</b>
<b>Total</b>	<b>92.0</b>

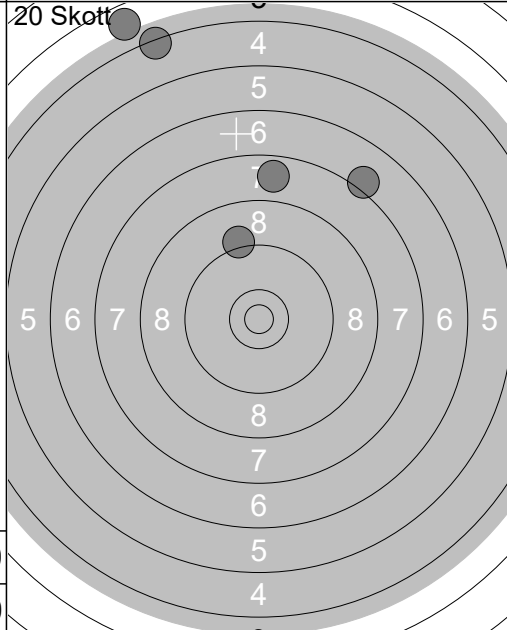

16:	7.1 ↗
17:	4.4 ↑
18:	3.7 ↖
19:	9.2 ↑
20:	7.7 ↑
<b>Serie</b>	<b>30.0</b>
<b>Total</b>	<b>122.0</b>



	<p>1: 10.0 →</p> <p>2: 10.7x ↗</p> <p>3: 10.3 ↗</p> <p>4: 10.4x ↗</p> <p>5: 9.7 ↘</p> <p>6: 10.6x ↘</p> <p>7: 10.3x ↘</p> <p>8: 9.7 ↙</p> <p>9: 10.1 ↑</p> <p>10: 9.7 ↑</p>	<p>20 Skott</p>
<b>Serie</b> 97.0	<b>Serie</b> 46.0	
<b>Total</b> 0.0	<b>Total</b> 46.0	

<p>20 Skott</p>	<p>6: 10.4x ↘</p> <p>7: 10.1 ↘</p> <p>8: 10.1 ↘</p> <p>9: 9.8 ↙</p> <p>10: 9.4 ↙</p>	<p>20 Skott</p>
<b>Serie</b> 48.0	<b>Serie</b> 32.0	
<b>Total</b> 94.0	<b>Total</b> 126.0	

<p>20 Skott</p>	<p>16: 5.6 ↑</p> <p>17: 8.8 ↗</p> <p>18: 7.1 ↘</p> <p>19: 5.0 ←</p> <p>20: 9.6 ↓</p>	
<b>Serie</b> 34.0		
<b>Total</b> 160.0		

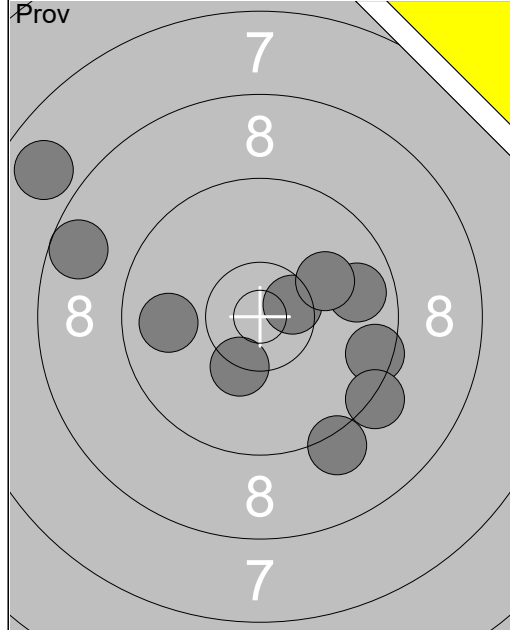

1:	9.8	➔
2:	9.5	➔
3:	8.6	↖
4:	9.3	↘
5:	9.2	↘
6:	10.3x	↘
7:	7.8	↖
8:	10.5x	➔
9:	10.1	➔
10:	9.9	↖
Serie		90.0
Total		0.0

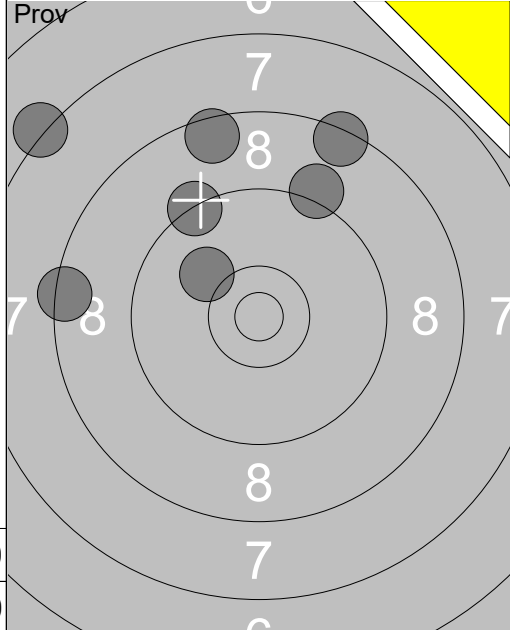

11:	10.1	↖
12:	9.3	↖
13:	9.2	↗
14:	8.5	↗
15:	8.4	↖
16:	7.2	↖
17:	8.4	↗
Serie		59.0
Total		0.0

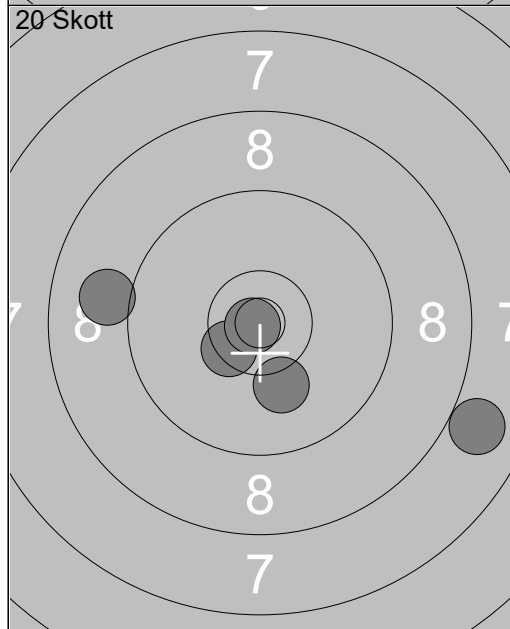

1:	10.4x	↘
2:	10.1	↘
3:	7.9	➔
4:	9.0	↖
5:	10.9x	↖
Serie		46.0
Total		46.0

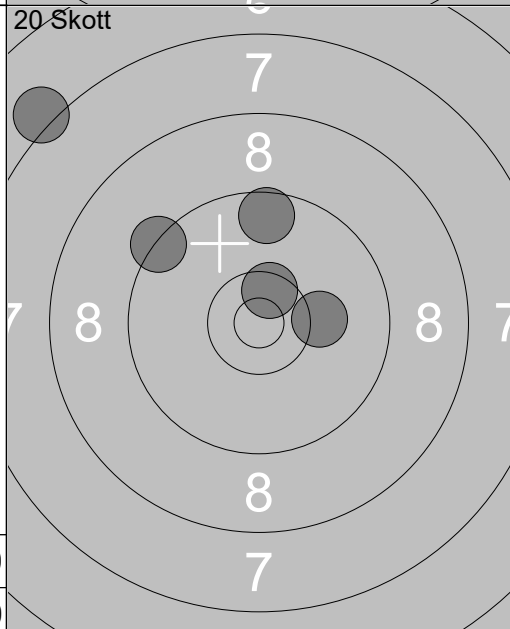

6:	7.1	↖
7:	10.2	➔
8:	10.5x	↗
9:	9.3	↖
10:	9.6	↗
Serie		45.0
Total		91.0

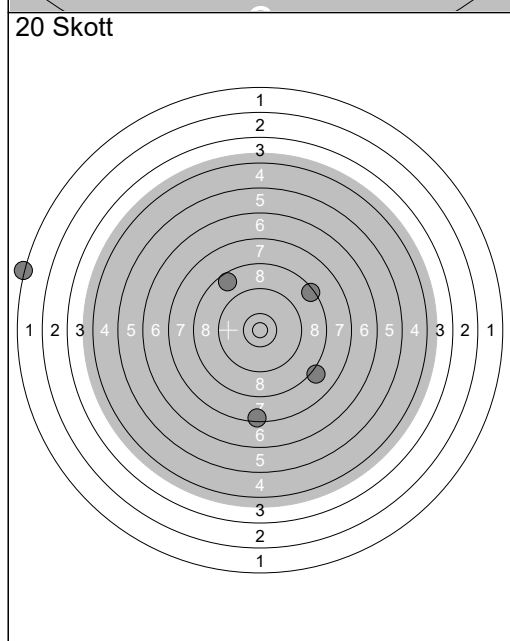

11:	8.4	↗
12:	8.6	↖
13:	8.1	↘
14:	7.5	↘
15:	1.3	↖
Serie		32.0
Total		123.0

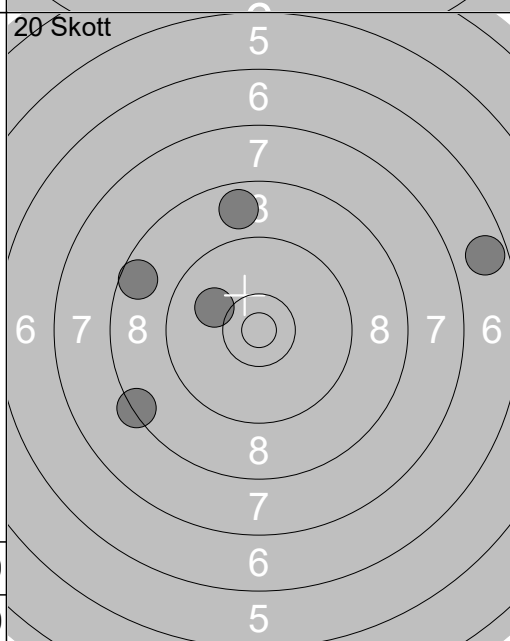

16:	8.4	↖
17:	8.6	↖
18:	10.1	↖
19:	6.7	➔
20:	8.8	↗
Serie		40.0
Total		163.0

1: 6.5 → 2: 8.8 → 3: 7.8 ↗ 4: 9.9 ↑ 5: 8.9 → 6: 8.7 → 7: 10.1 ↓ 8: 9.0 ↑ 9: 8.8 ↑ 10: 8.9 ↖ Serie 81.0 Total 0.0	11: 7.7 ← 12: 9.4 ↑ 13: 9.3 ← 14: 10.2 ← Serie 35.0 Total 0.0	

20 Skott 1: 10.3x ↑ 2: 10.8x ↗ 3: 8.7 ↓ 4: 8.6 ← 5: 8.3 ← Serie 44.0 Total 44.0	20 Skott 6: 8.7 ← 7: 9.9 ↗ 8: 10.7x ↓ 9: 9.9 ← 10: 10.5x → Serie 46.0 Total 90.0	

20 Skott 11: 8.6 ↖ 12: 10.1 ↘ 13: 6.4 ↓ 14: 8.4 ↑ 15: 10.2 → Serie 42.0 Total 132.0	20 Skott 16: 10.0 ↑ 17: 6.9 ← 18: 9.3 ↑ 19: 9.8 → 20: 9.9 ↓ Serie 43.0 Total 175.0	

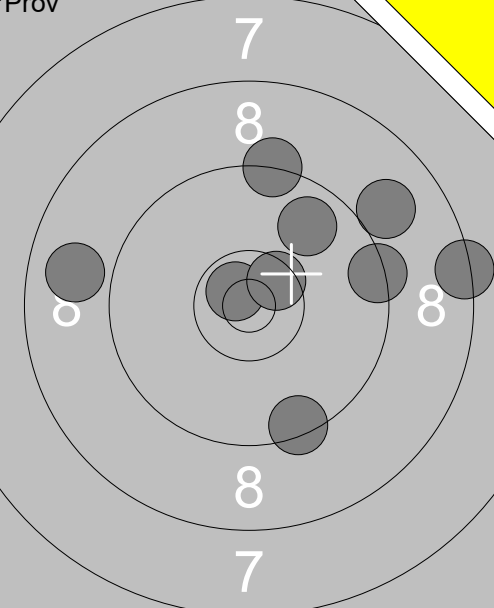
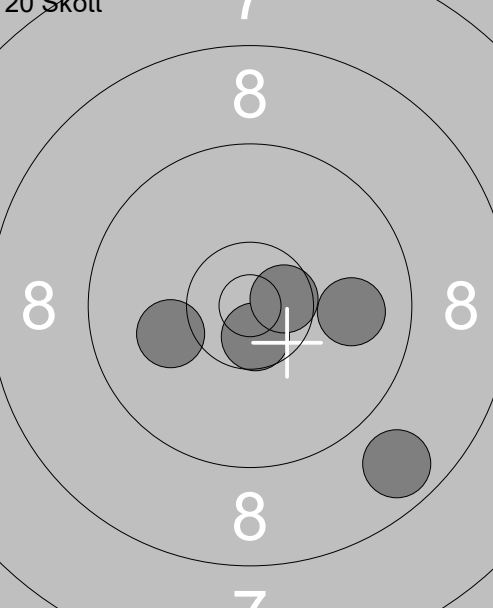
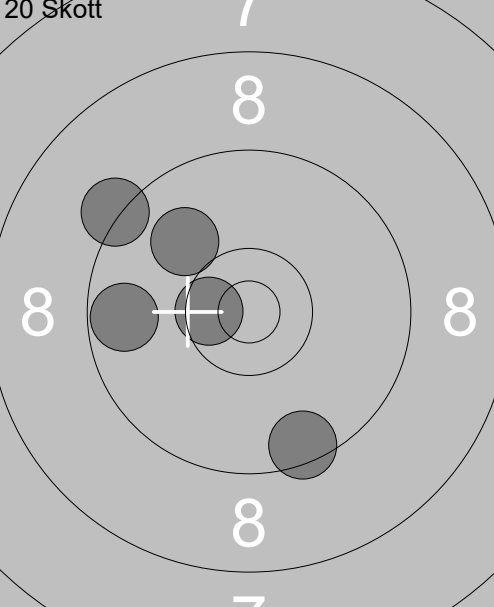
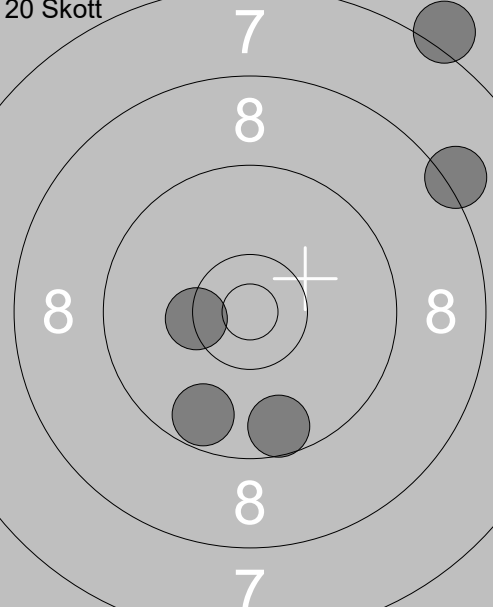
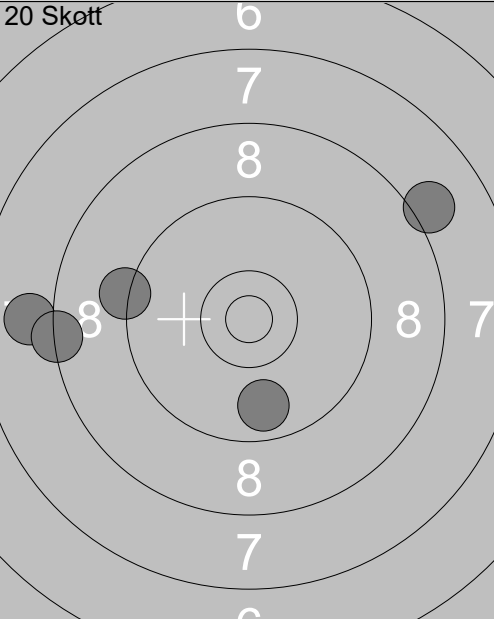
Prov 	1: 9.4 ↓ 2: 9.4 → 3: 8.4 → 4: 9.0 ↗ 5: 10.7x↘ 6: 9.8 ↗ 7: 9.3 ↑ 8: 10.5x↗ 9: 8.9 ← <hr/> Serie 81.0 Total 0.0	20 Skott 		1: 9.9 → 2: 8.8 ↓ 3: 10.6x↓ 4: 10.6x→ 5: 10.1 ← <hr/> Serie 47.0 Total 47.0
20 Skott 	6: 9.3 ↖ 7: 10.5x← 8: 10.0 ↖ 9: 9.7 ← 10: 9.5 ↓ <hr/> Serie 47.0 Total 94.0	20 Skott 		11: 8.2 ↗ 12: 7.1 ↗ 13: 10.3x← 14: 9.7 ↓ 15: 9.6 ↓ <hr/> Serie 43.0 Total 137.0
20 Skott 	16: 8.0 ← 17: 9.2 ← 18: 8.1 ↗ 19: 9.8 ↓ 20: 8.3 ← <hr/> Serie 42.0 Total 179.0			

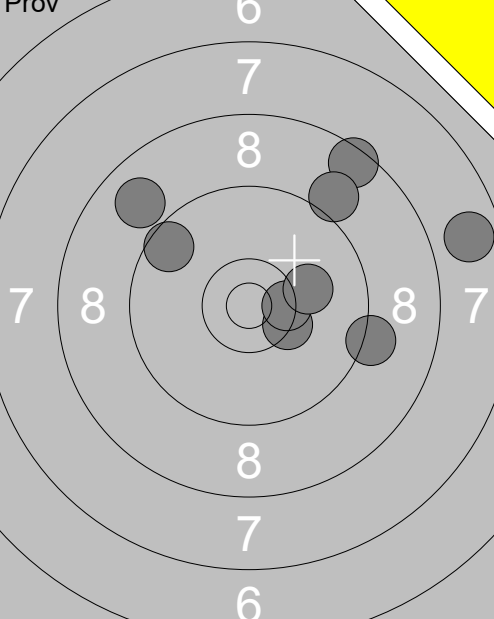
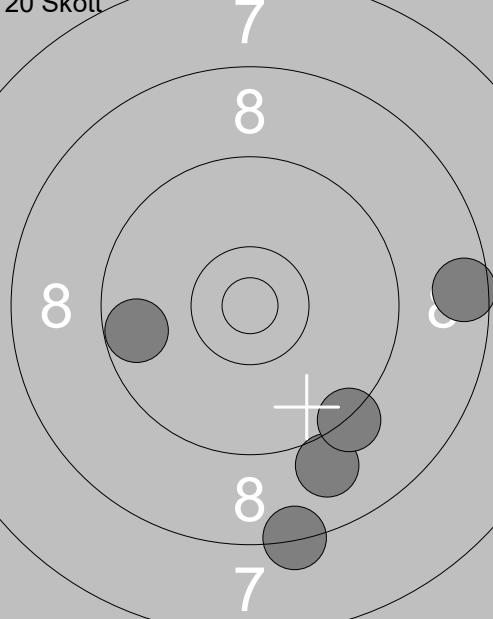
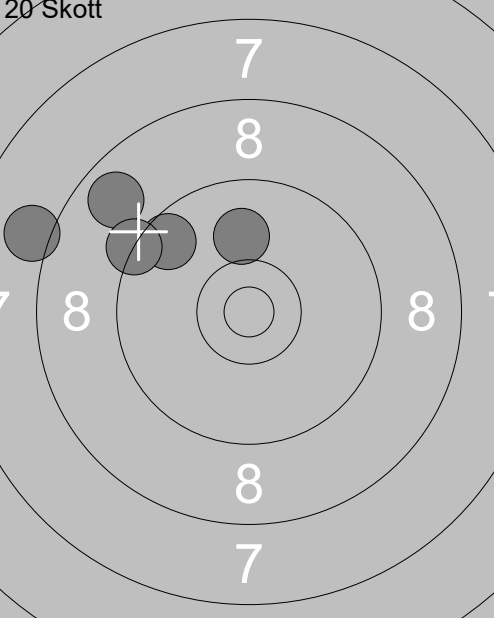
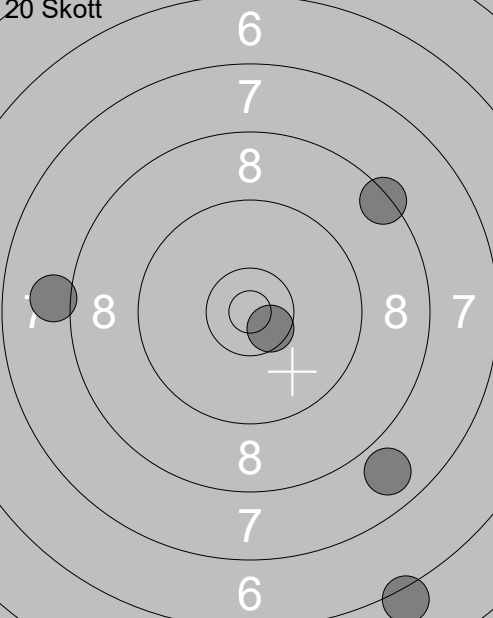
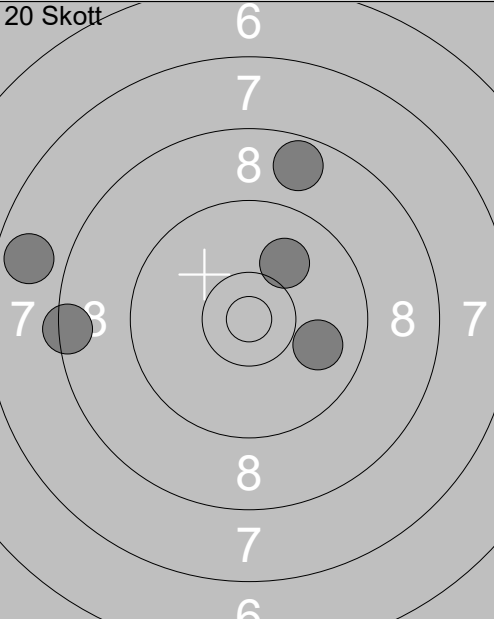
 <p>Prov</p>	<p>1: 10.4x↘ 2: 10.4x→ 3: 9.2 → 4: 7.8 → 5: 8.9 ↖ 6: 8.5 ↗ 7: 9.0 ↗ 8: 10.1 → 9: 9.6 ↖</p>	 <p>20 Skott</p>	<p>1: 8.6 → 2: 9.0 ↓ 3: 8.3 ↓ 4: 9.3 ↓ 5: 9.7 ←</p>
Serie 80.0		Serie 43.0	
Total 0.0		Total 43.0	
 <p>20 Skott</p>	<p>6: 9.6 ↖ 7: 8.8 ↖ 8: 8.1 ← 9: 9.3 ↖ 10: 10.0 ↑</p>	 <p>20 Skott</p>	<p>11: 10.6x↘ 12: 8.4 ↗ 13: 6.1 ↓ 14: 8.0 ← 15: 7.8 ↓</p>
Serie 44.0		Serie 39.0	
Total 87.0		Total 126.0	
 <p>20 Skott</p>	<p>16: 8.4 ← 17: 10.0 ↗ 18: 9.9 → 19: 7.8 ← 20: 8.7 ↑</p>		
Serie 42.0			
Total 168.0			

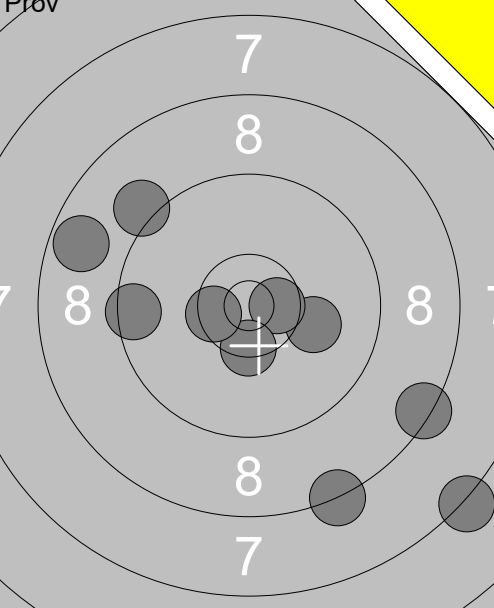
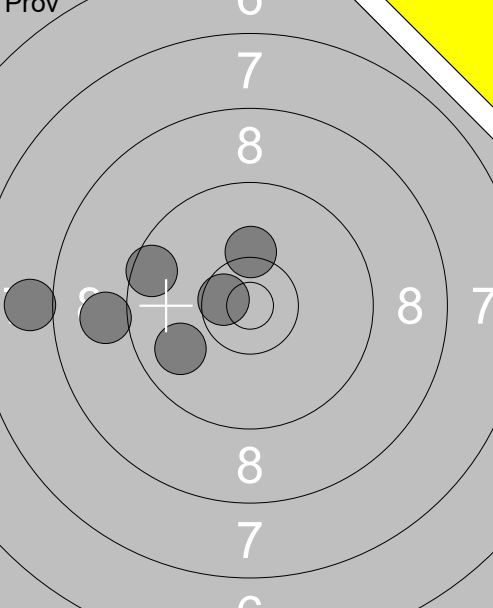
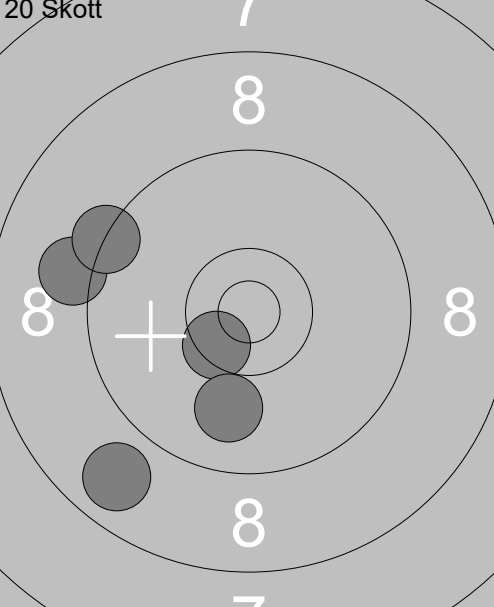
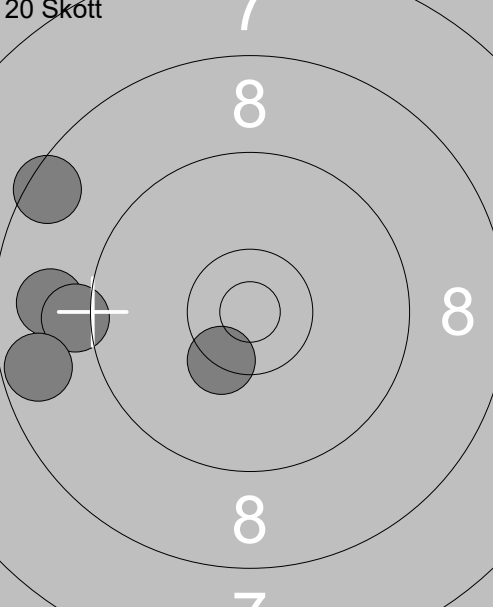
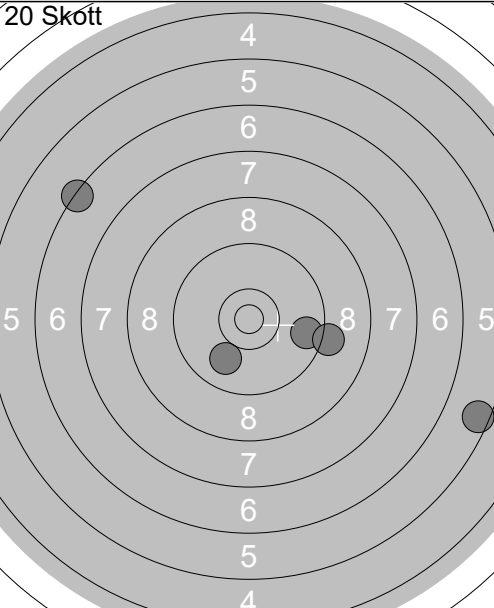
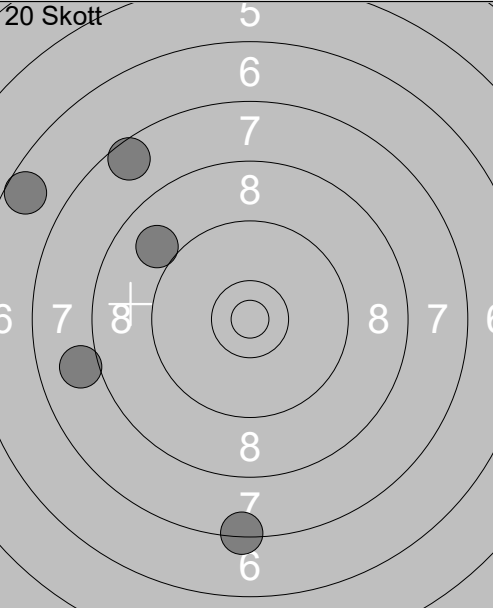
<p>Prov</p> 	<p>1: 8.4 ↘ 2: 7.3 ↘ 3: 10.1 → 4: 8.3 ↘ 5: 10.6x → 6: 10.4x ↓ 7: 10.5x ← 8: 9.5 ← 9: 8.7 ← 10: 9.1 ↖</p> <p>Serie 89.0 Total 0.0</p>	<p>Prov</p> 	<p>11: 9.9 ↙ 12: 10.2 ↑ 13: 9.0 ← 14: 8.0 ← 15: 10.6x ← 16: 9.6 ←</p> <p>Serie 55.0 Total 0.0</p>
<p>20 Skott</p> 	<p>1: 10.5x ↘ 2: 9.9 ↓ 3: 9.1 ← 4: 9.3 ← 5: 8.8 ↘</p> <p>Serie 45.0 Total 45.0</p>	<p>20 Skott</p> 	<p>6: 10.4x ↘ 7: 8.5 ↖ 8: 8.9 ← 9: 9.1 ← 10: 8.7 ←</p> <p>Serie 43.0 Total 88.0</p>
<p>20 Skott</p> 	<p>11: 9.7 → 12: 10.0 ↘ 13: 5.5 → 14: 6.4 ↖ 15: 9.2 →</p> <p>Serie 39.0 Total 127.0</p>	<p>20 Skott</p> 	<p>16: 7.6 ↖ 17: 6.6 ← 18: 7.4 ↓ 19: 9.0 ↖ 20: 8.0 ←</p> <p>Serie 37.0 Total 164.0</p>

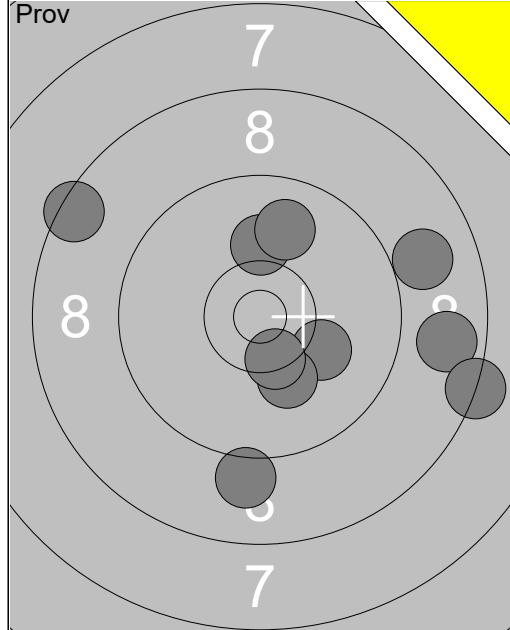

1:	8.8	→
2:	8.9	→
3:	8.3	→
4:	10.1	↑
5:	10.1	↘
6:	9.9	↑
7:	10.2	↓
8:	9.1	↓
9:	8.5	↙
10:	10.4	↘
Serie	90.0	
Total	0.0	

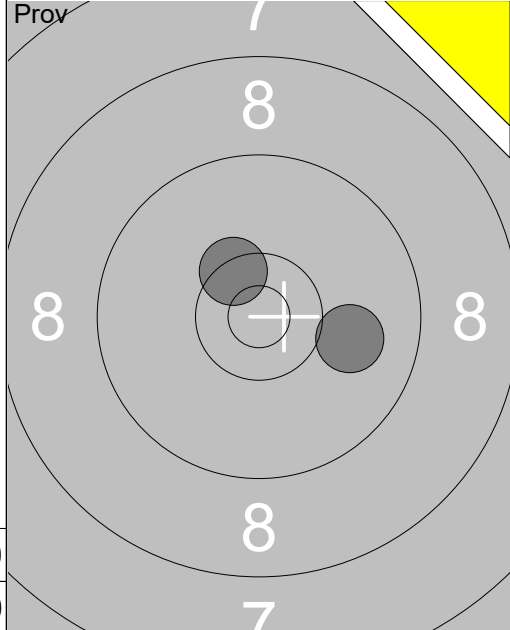

11:	10.0	→
13:	10.4	↘
Serie	20.0	
Total	0.0	

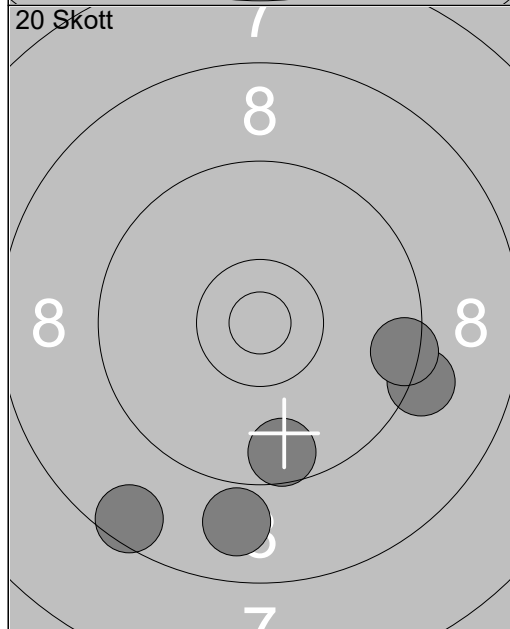

1:	9.6	↓
2:	8.9	↓
3:	9.2	→
4:	9.5	→
5:	8.6	↘
Serie	43.0	
Total	43.0	

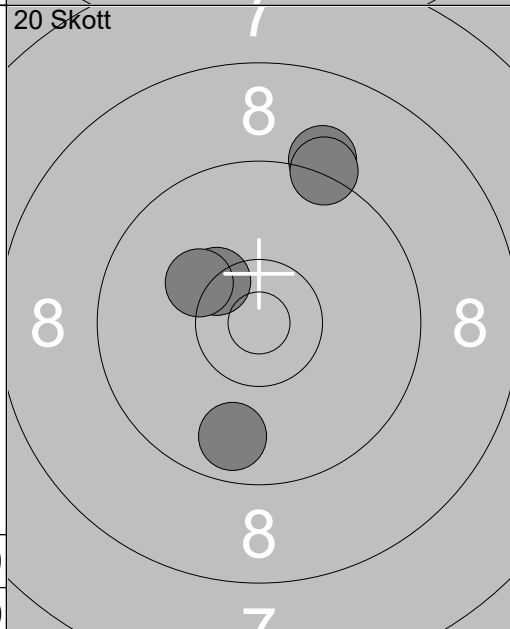

6:	10.3	↘
7:	9.2	↑
8:	9.3	↑
9:	9.8	↓
10:	10.2	↙
Serie	47.0	
Total	90.0	

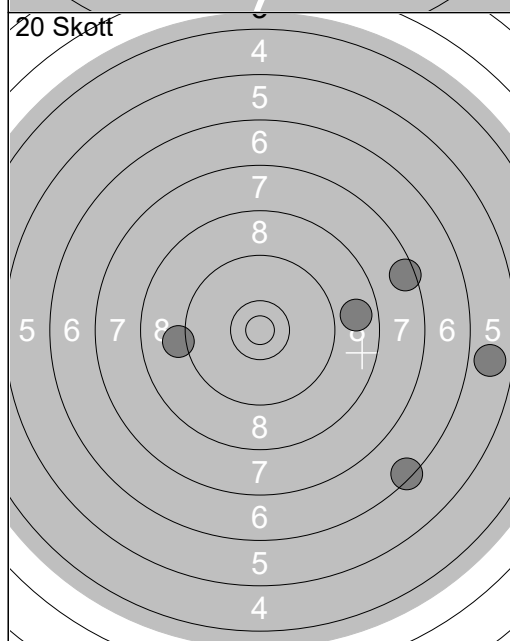

11:	6.4	↘
12:	8.8	→
13:	5.8	→
14:	7.5	→
15:	9.1	←
Serie	35.0	
Total	125.0	

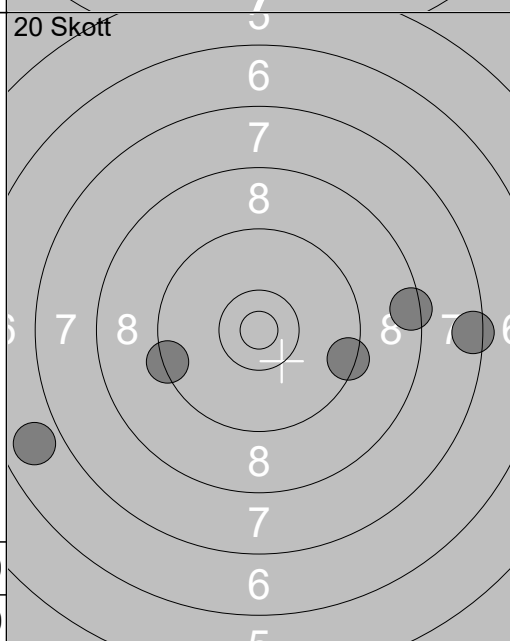

16:	7.5	→
17:	8.4	→
18:	6.8	↙
19:	9.4	↙
20:	9.4	→
Serie	39.0	
Total	164.0	

	<p>1: 9.1 →</p> <p>2: 7.9 ↗</p> <p>3: 8.9 ↑</p> <p>4: 8.6 →</p> <p>5: 8.0 →</p> <p>6: 10.3 →</p> <p>7: 10.1 ↗</p> <p>8: 9.8 ↓</p> <p>9: 9.2 ←</p> <p>10: 10.1 ↘</p>	<p>20 Skott</p>	<p>1: 8.7 ↘</p> <p>2: 10.3x ↘</p> <p>3: 10.1 →</p> <p>4: 10.5x →</p> <p>5: 10.7x ↑</p>
Serie 88.0		Serie 48.0	
Total 0.0		Total 48.0	

<p>20 Skott</p>	<p>6: 8.9 →</p> <p>7: 10.3x ↗</p> <p>8: 9.2 ↘</p> <p>9: 9.8 ↑</p> <p>10: 9.7 ↗</p>	<p>20 Skott</p>	<p>11: 9.0 ↑</p> <p>12: 7.2 ↘</p> <p>13: 9.9 →</p> <p>14: 9.8 ↘</p> <p>15: 9.8 ↘</p>
Serie 45.0		Serie 43.0	
Total 93.0		Total 136.0	

<p>20 Skott</p>	<p>16: 9.2 →</p> <p>17: 10.8x ↑</p> <p>18: 3.7 ←</p> <p>19: 9.3 ←</p> <p>20: 8.6 →</p>		
Serie 39.0			
Total 175.0			

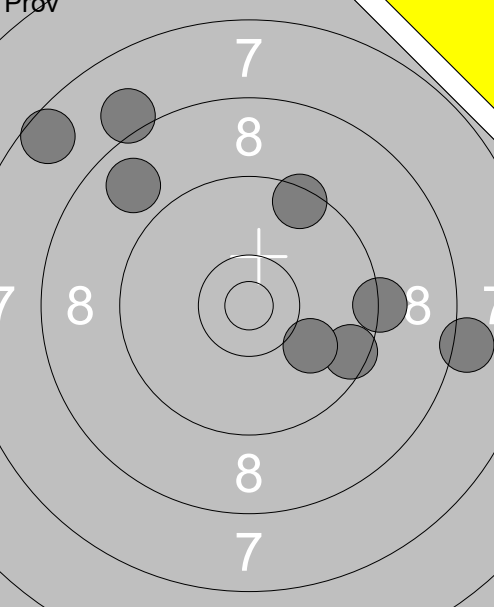
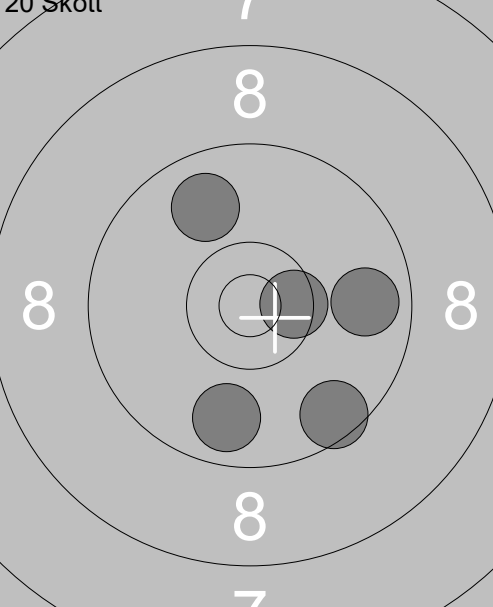

<p>Prov</p> <p>1: 8.8 → 2: 9.1 → 3: 10.9x ↘ 4: 10.8x ↘ 5: 9.4 → 6: 10.4x → 7: 9.1 ← 8: 9.6 ← 9: 9.9 ↗ 10: 9.0 ↓</p> <p>Serie 92.0 Total 0.0</p>	<p>Prov</p> <p>11: 7.9 → 12: 10.4x → 13: 10.0x ↘ 14: 9.8x ↗ 15: 9.5 ↗ 16: 10.8x ↘ 17: 9.1 ←</p> <p>Serie 7.0 Total 0.0</p>
<p>20 Skott</p> <p>1: 9.6 → 2: 10.1 ↖ 3: 9.8 ← 4: 9.0 ↗ 5: 9.4 ↑</p> <p>Serie 46.0 Total 46.0</p>	<p>20 Skott</p> <p>6: 10.0 ↘ 7: 9.8 ↗ 8: 9.5 ↗ 9: 10.8x ↘ 10: 9.1 ←</p> <p>Serie 47.0 Total 93.0</p>
<p>20 Skott</p> <p>11: 0.0 ↗ 12: 6.9 ↘ 13: 4.8 ↑ 14: 10.0 ↘ 15: 7.6 ↘</p> <p>Serie 27.0 Total 120.0</p>	<p>20 Skott</p> <p>16: 8.1 ↖ 17: 7.4 ↖ 18: 9.1 ↑ 19: 8.8 ↓ 20: 10.2 ↙</p> <p>Serie 42.0 Total 162.0</p>

	1: 9.5 ➤		1: 10.5x➤
	2: 9.5 ↗		2: 9.8 ➔
	3: 8.1 ➔		3: 9.8 ↓
	4: 9.3 ➔		4: 9.6 ↓
	5: 7.6 ↗		5: 9.9 ↗
	6: 8.8 ↗		
	7: 8.1 ↗		
	8: 10.0 ➤		
	Serie 68.0		Serie 46.0
	Total 0.0		Total 46.0

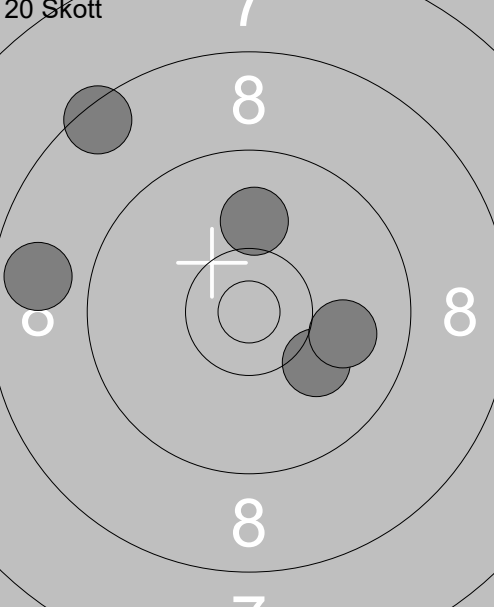
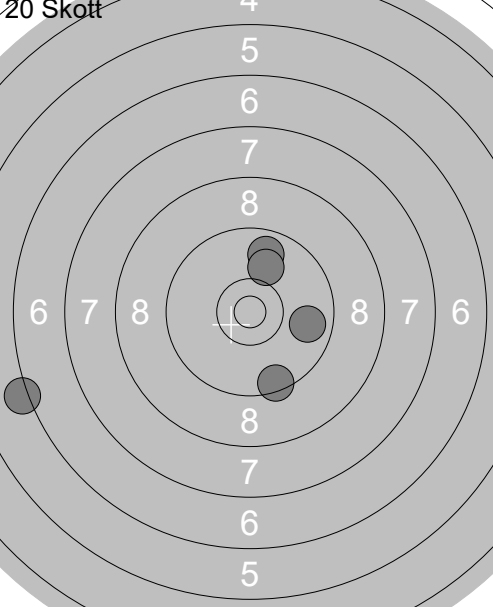
	6: 8.8 ←		11: 6.2 ←
	7: 10.0 ↑		12: 9.8 ↗
	8: 8.5 ↗		13: 9.8 ➔
	9: 10.1 ➤		14: 9.5 ↓
	10: 10.0 ➔		15: 10.0 ↗
	Serie 46.0		Serie 43.0
	Total 92.0		Total 135.0

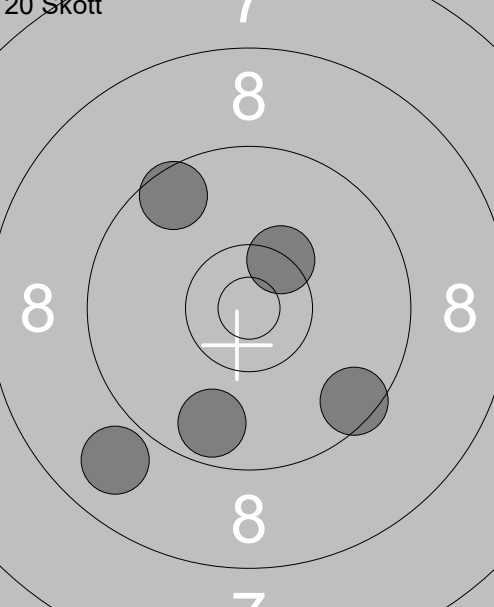
	16: 9.5 ➤		
	17: 10.4x↗		
	18: 8.9 ↓		
	19: 9.7 ↓		
	20: 9.6 ↗		
	Serie 45.0		
	Total 180.0		

Prov 	1: 10.0 → 2: 10.2 ↘ 3: 9.9 ↘ 4: 9.8 ↘ 5: 9.4 → 6: 10.8x ↗ 7: 9.9 ↘ 8: 9.4 ↘ 9: 9.3 ← 10: 9.6 ←	Serie 93.0 Total 0.0	Prov 	11: 9.9 ↙ 12: 10.5x ↑ 13: 10.2 ↑ 14: 9.9 ← 15: 9.9 ↗	Serie 47.0 Total 0.0			
	20 Skott 			1: 8.7 ↘ 2: 9.0 ↗ 3: 9.1 ← 4: 8.7 → 5: 8.8 →	Serie 42.0 Total 42.0	20 Skott 	6: 10.0 ↓ 7: 10.0 ↘ 8: 9.6 ↗ 9: 9.8 ↓ 10: 8.6 ↘	Serie 46.0 Total 88.0
	20 Skott 			11: 10.4x ↗ 12: 10.1 ↑ 13: 9.5 ↘ 14: 9.2 ↗ 15: 8.3 ↘	Serie 46.0 Total 134.0	20 Skott 	16: 8.3 ↗ 17: 9.5 ↗ 18: 8.4 ← 19: 10.6x ↑ 20: 10.1 ↑	Serie 45.0 Total 179.0

	<p>1: 7.6 →</p> <p>2: 10.3 →</p> <p>3: 8.9 →</p> <p>4: 8.7 →</p> <p>5: 10.0 ↗</p> <p>6: 8.9 →</p> <p>7: 10.5x →</p> <p>8: 10.3x ↓</p> <p>9: 10.1 ↖</p> <p>10: 10.4x ↗</p>		<p>11: 9.5 ↓</p> <p>12: 9.9 ↖</p> <p>13: 10.4x ↗</p>
<b>Serie</b> 91.0	<b>Serie</b> 28.0	<b>Serie</b> 28.0	<b>Serie</b> 28.0
<b>Total</b> 0.0	<b>Total</b> 0.0	<b>Total</b> 0.0	<b>Total</b> 0.0
<p>20 Skott</p>	<p>1: 9.6 →</p> <p>2: 9.7 →</p> <p>3: 10.4x ↖</p> <p>4: 10.8x ↗</p> <p>5: 10.5x ↓</p>	<p>20 Skott</p>	<p>6: 10.3 ↗</p> <p>7: 10.1 ↗</p> <p>8: 10.0 ↙</p> <p>9: 10.2 ↙</p> <p>10: 9.7 ←</p>
<b>Serie</b> 48.0	<b>Serie</b> 48.0	<b>Serie</b> 49.0	<b>Serie</b> 49.0
<b>Total</b> 48.0	<b>Total</b> 48.0	<b>Total</b> 97.0	<b>Total</b> 97.0
<p>20 Skott</p>	<p>11: 8.0 ↑</p> <p>12: 9.0 →</p> <p>13: 9.6 ↓</p> <p>14: 8.5 ↑</p> <p>15: 8.7 ↖</p>	<p>20 Skott</p>	<p>16: 9.6 ↓</p> <p>17: 8.9 ↙</p> <p>18: 9.1 ↙</p> <p>19: 8.4 ↗</p> <p>20: 9.9 ↗</p>
<b>Serie</b> 42.0	<b>Serie</b> 42.0	<b>Serie</b> 43.0	<b>Serie</b> 43.0
<b>Total</b> 139.0	<b>Total</b> 139.0	<b>Total</b> 182.0	<b>Total</b> 182.0

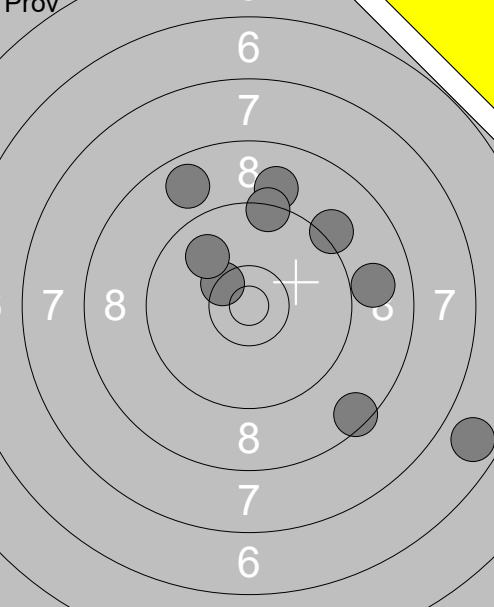
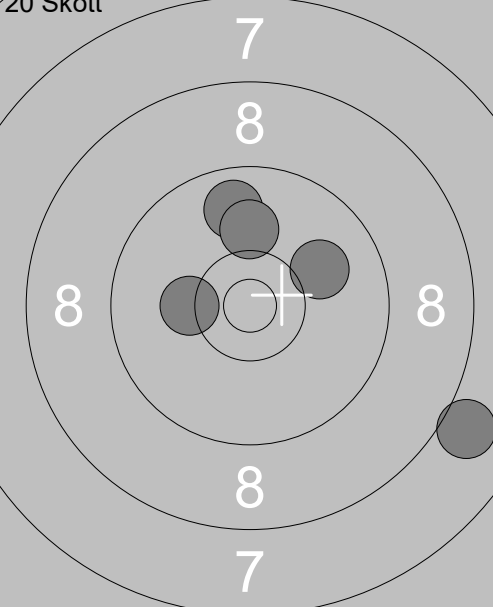
<p>Prov</p> 	<p>20 Skott</p> 	
<p>1: 8.5 ↘ 2: 6.8 ↘ 3: 8.9 → 4: 9.2 ↗ 5: 10.4 ✕ 6: 9.0 ↑ 7: 9.4 ↑ 8: 9.9 ↖ 9: 8.8 ↖</p>	<p>1: 8.0 ↘ 2: 10.2 ← 3: 9.8 ↑ 4: 10.0 ↑ 5: 10.0 ↗</p>	
Serie 76.0		Serie 47.0
Total 0.0		Total 47.0

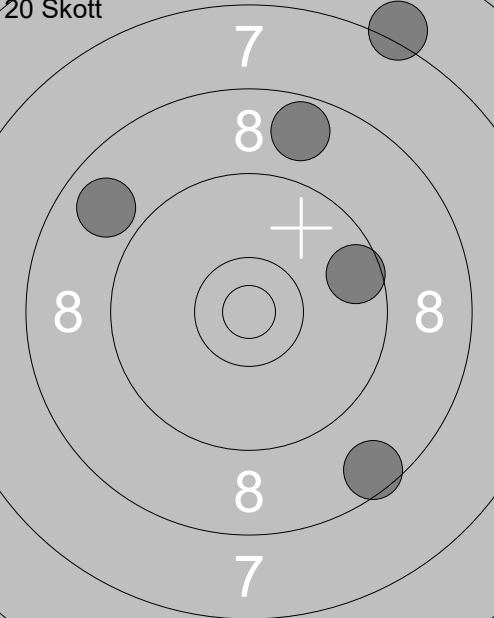
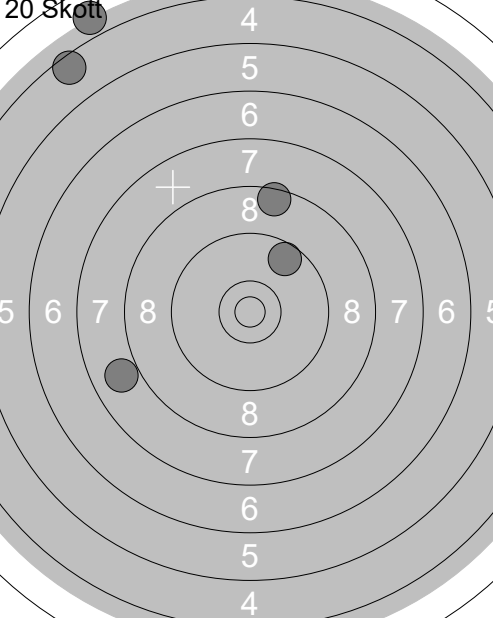
<p>20 Skott</p> 	<p>20 Skott</p> 	
<p>6: 8.6 ↘ 7: 7.2 ↑ 8: 9.6 → 9: 8.7 ↑ 10: 8.8 ↖</p>	<p>11: 7.9 ← 12: 4.5 ↖ 13: 3.9 ↖ 14: 9.6 ↗ 15: 8.5 ↑</p>	
Serie 40.0		Serie 31.0
Total 87.0		Total 118.0

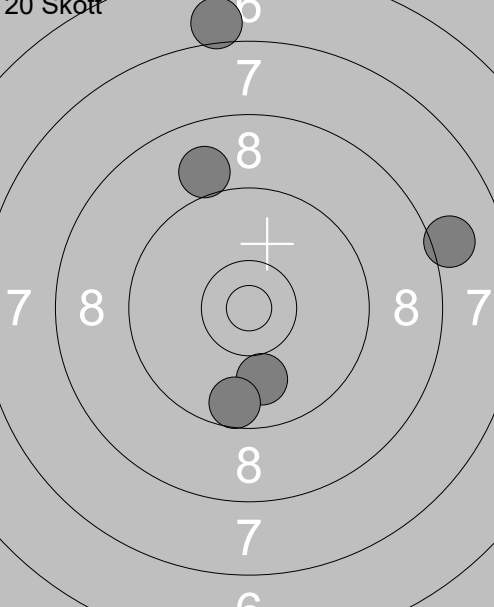
<p>20 Skott</p> 		
<p>16: 10.0 ↓ 17: 9.6 ↓ 18: 7.0 ↑ 19: 8.1 → 20: 9.0 ↑</p>		
Serie 43.0		
Total 161.0		

	1: 7.5 →		1: 8.8 ↓
	2: 9.5 ↓		2: 8.2 →
	3: 9.0 →		3: 10.2 ↑
	4: 8.4 ↓		4: 9.3 ↖
	5: 9.3 →		5: 9.1 ↑
	6: 10.8x ↓		
	7: 10.3 ↗		
	8: 9.0 →		
	9: 9.4 ↓		
	10: 8.6 ←		
	Serie 88.0		Serie 44.0
	Total 0.0		Total 44.0

	6: 8.0 ↖		11: 5.0 ↙
	7: 9.3 ↑		12: 5.9 ←
	8: 10.1 ↗		13: 4.6 ↙
	9: 10.2 ↓		14: 9.5 ↓
	10: 10.8x ↓		15: 7.6 ↗
	Serie 47.0		Serie 30.0
	Total 91.0		Total 121.0

	16: 10.4x ↑	
	17: 9.5 ←	
	18: 6.5 ↓	
	19: 10.2 →	
	20: 9.0 ↓	
	Serie 44.0	
	Total 165.0	